

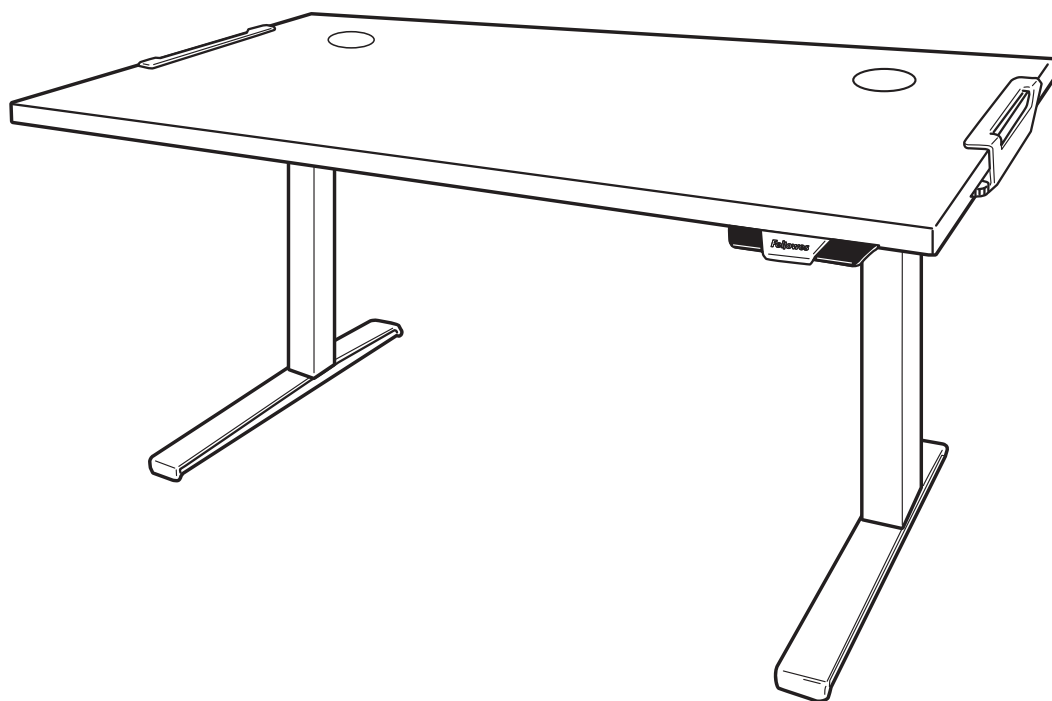

## Levado™ Height Adjustable Desk Base



PLEASE READ INSTRUCTIONS BEFORE USE.  
DO NOT DISCARD.

LIRE LES INSTRUCTIONS AVANT UTILISATION.  
NE PAS JETER.

LEA LAS INSTRUCCIONES ANTES DEL USO.  
NO TIRAR.

BITTE LESEN SIE DIE ANLEITUNGEN SORGFÄLTIG DURCH,  
BEVOR SIE DAS GERÄT BENUTZEN.  
BITTE GUT AUFBEWAHREN.

LEGGERE LE ISTRUZIONI PRIMA DELL'USO.  
NON GETTARE.

LEES DE INSTRUCTIES VOOR GEBRUIK.  
NIET WEGWERPEN.

LÄS DESSA INSTRUKTIONER FÖRE ANVÄNDNING.  
KASSERA EJ.

PRZED UŻYCIEM PROSZĘ PRZECZYTAĆ NINIEJSZĄ INSTRUKCJĘ.  
NIE WYRZUCAĆ.

ПЕРЕД ИСПОЛЬЗОВАНИЕМ ПРОСЬБА ОЗНАКОМИТЬСЯ С  
ИНСТРУКЦИЯМИ.  
НЕ ВЫБРАСЫВАТЬ.

LEIA AS INSTRUÇÕES ANTES DA UTILIZAÇÃO.  
NÃO AS ELIMINE.

### SAFETY INSTRUCTIONS/WARNING

#### WARNING: IMPORTANT SAFETY INSTRUCTIONS – Read Before Using!

- CAUTION: Lift hazard! Two people are required to move desk. Serious injury may occur.
- DO NOT EXCEED MAXIMUM STATED WEIGHT CAPACITY. SERIOUS INJURY OR PROPERTY DAMAGE MAY OCCUR.
- Do Not operate table if any part is damaged or defective.
- Do Not place obstacles in the desk's path.
- Do Not place objects under the desk that are taller than 610mm (24").
- Make sure the desk has proper clearance on all sides (at least 25mm (1")) to all surrounding walls and objects.
- Do Not sit or stand on the desk.
- Do Not disassemble the legs, control box or controller. Serious injury may occur.
- Ensure all cord lengths are long enough to accommodate all changes in height and follow cord routing instructions in this manual. Failure to follow these instructions may result in equipment damage or personal injury.
- Keep liquids away from all electrical components. Only clean electrical components with a dry cloth.
- For indoor use only
- Keep power cord away from sources of heat.
- Unplug desk before moving or servicing.
- Remove all equipment and accessories from the desk before moving.
- Keep children away from moving parts and underneath the desk.

#### Maximum Weight Including Table Top

≤ 100 kg  
≤ 220 lbs



### PARTS PROVIDED

- A Base x1
- B Clamp x2
- C Handset x1
- D Power cable x1
- E Cable Tray x1
- F Cable Management x4
- G 5mm Allen Key x1
- H M6 Phillips round head screw x14
- I M3 Phillips round head screws x2
- J Clamp Covers x2

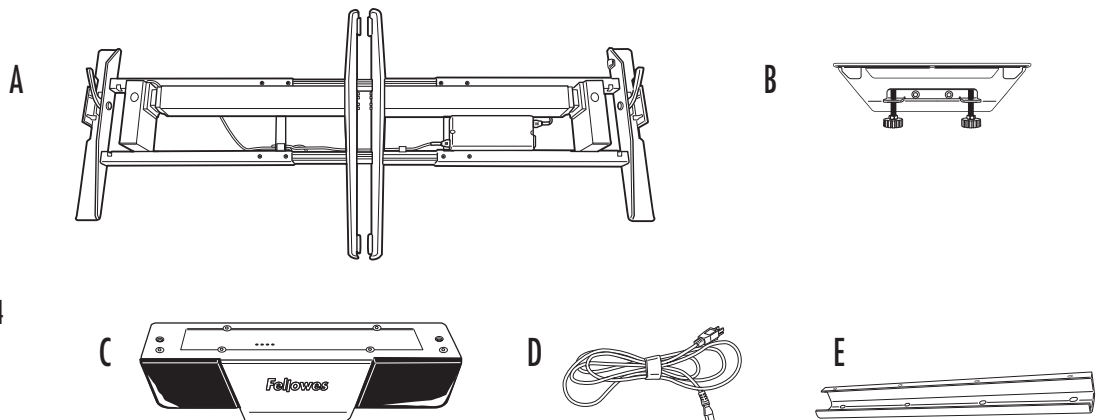

### Additional Tools Required

Phillips Screw Driver

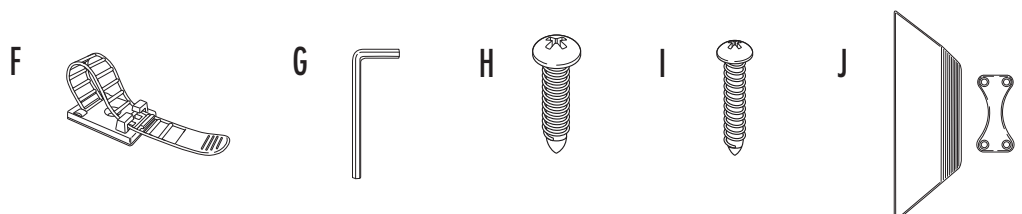

## INSTALL OPTION 1 - CLAMPS

### STEP 1

#### Unboxing

- Open box from the top.
- Ensure levers on base are in the upright position.
- Fold out legs until they click.  **WARNING:** Pinch Point! Keep hands and objects clear when lifting legs.
- Lock legs into place by pushing down on levers.
- Optional: If legs need to be folded, ensure lever is in the upright position and power is unplugged. Pull out pin and carefully guide legs to folded position.
- Using two people, flip the base upright.
- The base arrives adjusted for 1600mm (63") wide tables. If your table is not 1600mm (63") wide you will need to adjust the base width 1219mm – 1829mm (48" – 72"). See step 1B, otherwise move on to step 2.

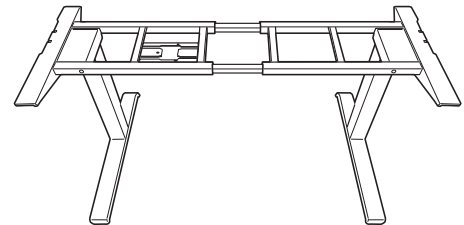
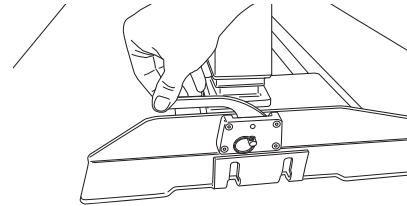
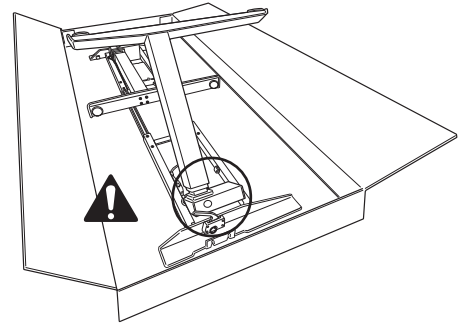

### STEP 1B - Only required if table is not 1600mm (63") wide

Adjust the cross channels to their final lengths

- Using two people, place table face down on a soft, clean surface and place base on table.
- Use the 5mm Allen key to loosen the (8) set screws on the inward side of the cross channels.
- Expand or contract the cross channels until flush with both ends of the desk. Free cables as necessary to allow the frame to adjust.
- Once properly adjusted, use the 5mm Allen key to re-tighten the set screws (8 total).
- Using two people, flip the base only upright.

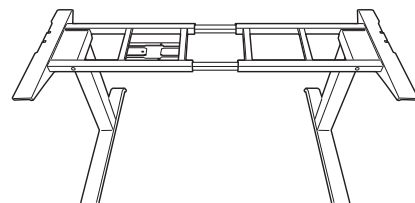
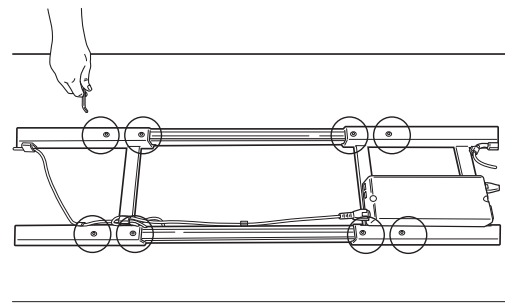
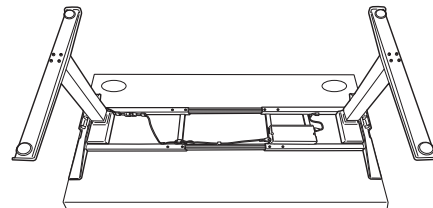

## STEP 2

Adjust the position of the frame before attaching it to the table

- Using two people, place the table top on the base.
- Check that the table top supports on each side are flush to both ends of the desktop and align to the predrilled holes on the desktop
- The rear cross channel will be 240mm (9.5") for 800mm (31.5") Depth Tops from the rear of the table

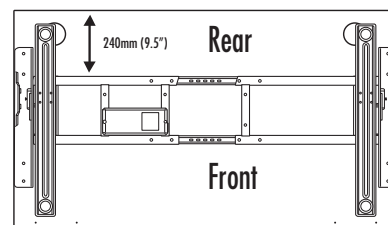
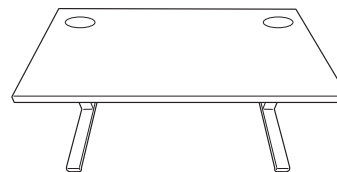

## STEP 3

Clamping base to table

- Slide clamps on each side of the table.
- On each clamp, tighten the (2) thumb screws until each click.

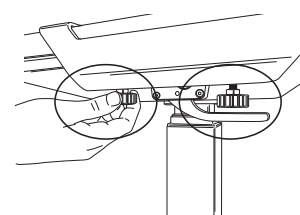
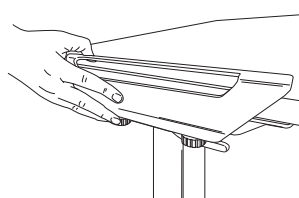
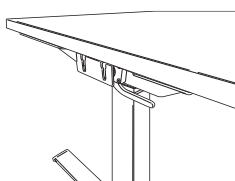

## INSTALL OPTION 2 - HARDWARE

### STEP 1

Preparing for installation using two people

- Place table face down on a soft, clean surface.
- Ensure levers on base are in the upright position.
- Fold out legs until they click,  **WARNING: Pinch Point!** Keep hands and objects clear when lifting legs.
- Lock legs into place by pushing down on levers.
- Optional: If legs need to be folded, ensure lever is in upright position and power is unplugged. Pull out pin and carefully guide legs to folded position.
- Lift base out of box and place on table.
- The base arrives adjusted for 1600mm (63") wide tables. If your table is not 1600mm (63") wide you will need to adjust the base width 1219mm – 1829mm (48" – 72"). See step 1B, otherwise move on to step 2.

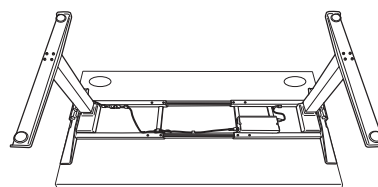
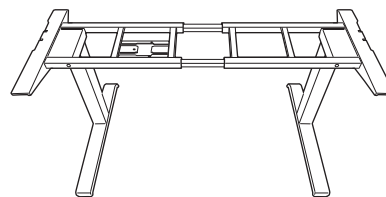
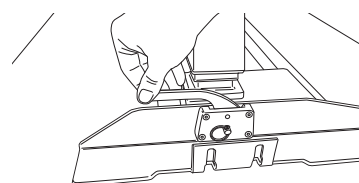
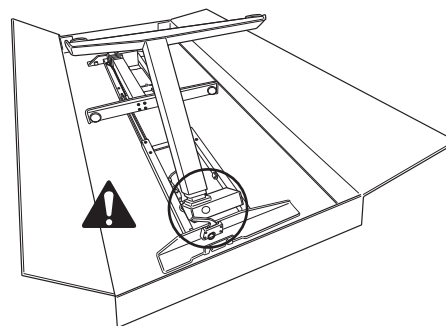

## STEP 1B - Only required if table is not 1600mm (63") wide

Adjust the cross channels to their final lengths

- Use the 5mm Allen key to loosen the (8) set screws on the inward side of the cross channels.
- Expand or contract the cross channels until flush with both ends of the desk. Free cables as necessary to allow the frame to adjust.
- Ensure proper alignment to predrilled holes on the desktop.
- Once properly adjusted, use the 5mm Allen key to re-tighten the set screws (8 total).

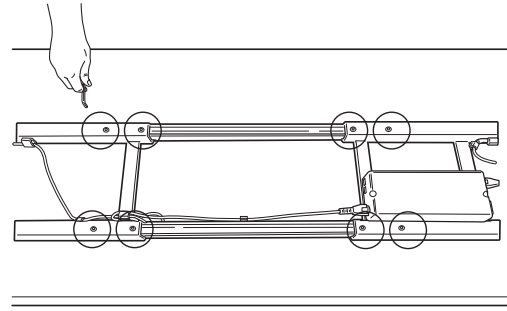

## STEP 2

Adjust the position of the frame before attaching it to the table.

- Check that the top supports on each side are flush to both ends of the desktop and align to the predrilled holes on the desktop.
- The rear cross channel will be 240mm (9.5") for 800mm (31.5") Depth Tops from the rear of the table.

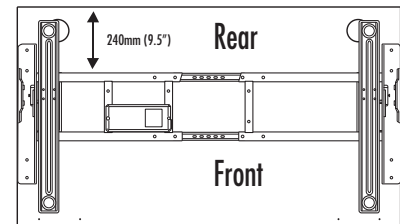

## STEP 3

Attach base to the table

- Use the M6 Phillips round head screws (10 total required) and a Phillips screwdriver.
- The screws fit through guides in the top of the supports and cross channel. Ensure proper alignment with predrilled holes on the desktop.
- Using two people, flip the Base and Table upright.
- Attach clamp covers to each side. Start by placing the smaller piece on the inside of the clamp bracket. Align the larger piece and apply pressure to secure.

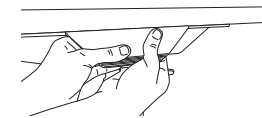
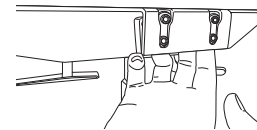
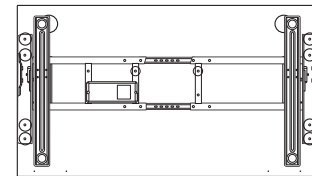

## ACCESSORY INSTALLATION

### STEP 1

Cable Management

- Position the cable tray in the center of the table towards the rear and align with pre-drilled holes on the desktop.
- Attach the cable tray with (4) M6 Phillips round head screws. The open end should face the rear.
- Use the additional provided cable management as needed.
- Cables must not interfere with table operation.
- Cables must not interfere with the user.

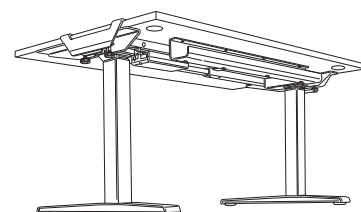
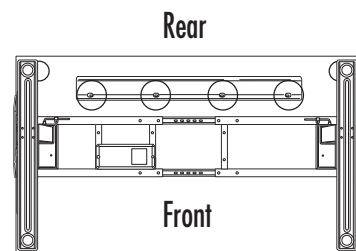

## STEP 2

Attach the handset using the included adhesive strip or using two M3 Phillips round head screws

- Position the handset on the left or right side of the table, according to user preference.
- Mount the handset flush to the front edge of the table. If using M3 attachment method, ensure handset is lined up to pre-drilled holes on the desktop.
- Plug handset into controller on base.
- Plug power cable into controller on base and into an power outlet.

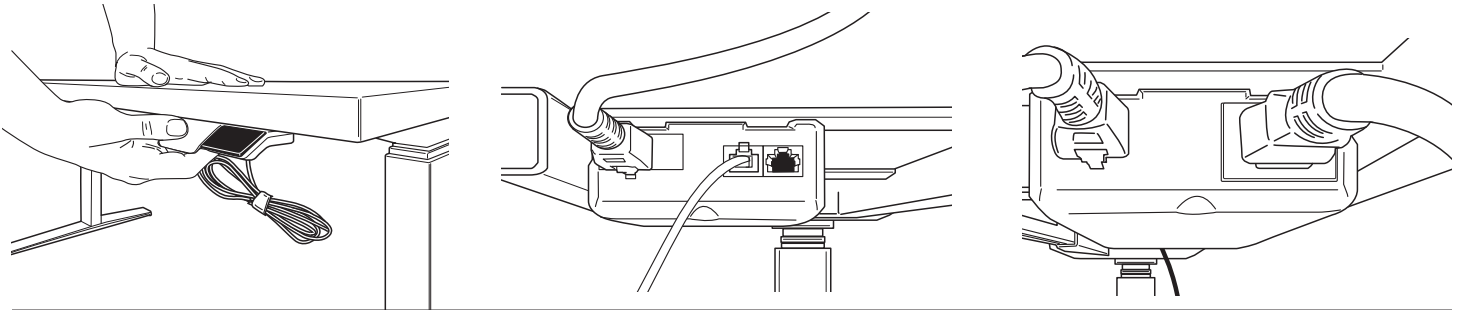

## STEP 3

Level Feet

- If table feels unbalanced adjust the (4) leveling pads located on bottom of feet
- Turn clockwise to lower and counterclockwise to raise

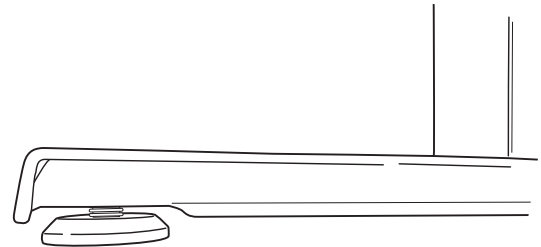

## OPERATING INSTRUCTIONS

### INITIALIZE THE SYSTEM

**IMPORTANT:** The initialization procedure below must be completed before operating the table.

**CAUTION:** Ensure proper clearance. Make sure all objects are clear of the table

- Press and hold down the paddle and M buttons simultaneously for 10-15 seconds.
- The legs will begin to move down at half speed of normal operation.
- Continue to hold the buttons.
- The legs will move down to the lowest position, then rebound 2mm to 5mm (1/16" to 3/16") and stop.
- Release both buttons at the same time. This completes the initialization procedure.
- If initialization is started and not finished, the table will not operate. You must finish the initialization process.

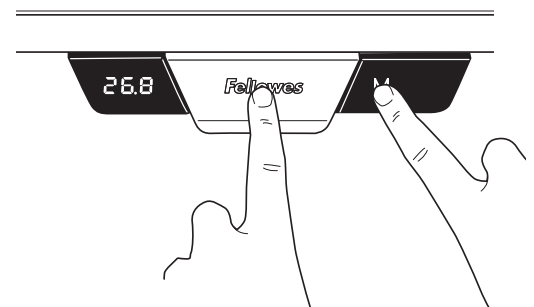

## GENERAL OPERATION

Move the table up or down by pressing down or pulling up on the lever until the work surface reaches the desired height.

The table will continue to move up or down until you release the button or until the maximum or minimum height is reached.

## MEMORY STOP POSITIONS

There are two groups of memory settings, each with two height settings. To toggle between the two users momentarily press the M button and display will read U1 or U2. Up to four memory stop positions can be used to save specific heights of the work surface. To set a specific position:

Raise or lower the table to the position you want to save.

Press and hold the M button for two seconds, the LED display will blink. This means it has stored the location. To clear storage settings, press and hold M button for 8 seconds until CLR displays.

## CHANGING THE HEIGHT DISPLAY UNITS

This function allows you to toggle the display units from inches to centimeters.

Press and hold up and down at same time for 10 seconds.

## RESET THE CONTROL UNIT TO FACTORY SETTINGS

Follow the same instructions to initialize the system.

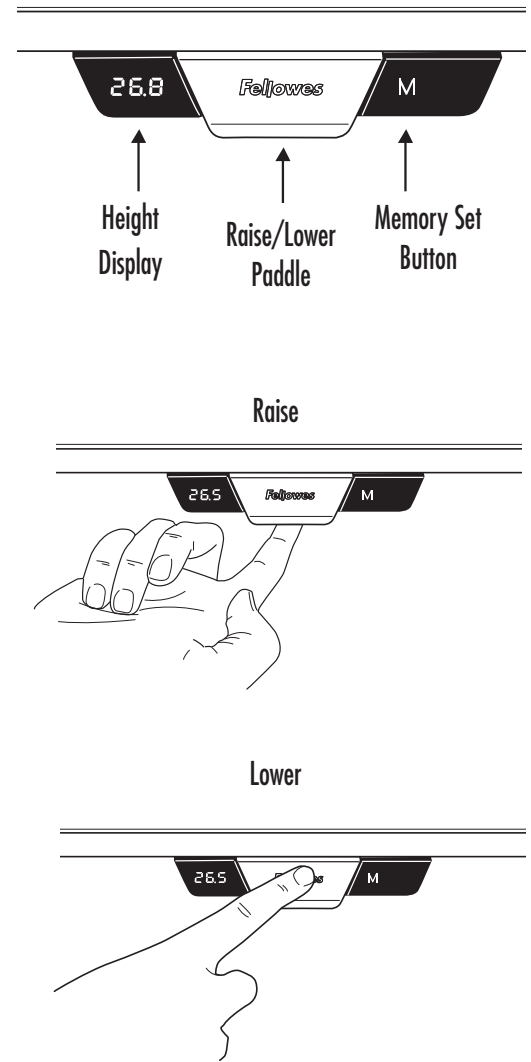

## FELLOWES LEVADO™ HEIGHT ADJUSTABLE DESK BASE LIMITED WARRANTY

Fellowes, Inc. (the "Company") warrants the Levado™ Height Adjustable Desk Base ("Product") to be free from defects in material and workmanship for the time period as set forth below.

The structural frame for a period of fifteen (15) years from the date of original purchase of the product.

All electrical components for a period of seven (7) years from the date of original purchase of the product.

This warranty applies only to the initial purchaser and does not cover claims resulting from misuse, failure to follow instructions on installation and use, neglect, use of unauthorized attachments, commercial use, use on a current or voltage other than specified on the product, or unauthorized service during the warranty period on conditions otherwise covered by warranty.

THE DURATION OF ANY IMPLIED WARRANTIES, INCLUDING BUT NOT LIMITED TO ANY IMPLIED WARRANTIES OF MERCHANTABILITY OR FITNESS FOR A PARTICULAR PURPOSE, IS EXPRESSLY LIMITED TO THE DURATION OF THIS LIMITED WARRANTY.

UNLESS REQUIRED BY APPLICABLE LAW, THE CUSTOMER'S EXCLUSIVE REMEDY FOR BREACH OF THIS WARRANTY OR ANY IMPLIED WARRANTY OR OF ANY OTHER OBLIGATION ARISING BY OPERATION OF LAW OR OTHERWISE SHALL BE LIMITED AS SPECIFIED HEREIN TO REPAIR, REPLACEMENT OR A REFUND OF THE PURCHASE PRICE, AT THE COMPANY'S SOLE OPTION.

UNDER NO CIRCUMSTANCE WILL THE COMPANY, ITS AFFILIATES, SUBSIDIARIES, RELATED ENTITIES, RESELLERS OR THEIR RESPECTIVE OFFICERS, DIRECTORS OR EMPLOYEES OR THOSE PERSONS FOR WHOM THEY ARE BY LAW RESPONSIBLE, BE LIABLE FOR CONSEQUENTIAL OR INCIDENTAL DAMAGES SUSTAINED IN CONNECTION WITH THE PRODUCT. THE COMPANY AND THESE OTHER PARTIES DO NOT ASSUME OR AUTHORIZE ANY REPRESENTATIVE OR OTHER PERSON TO ASSUME FOR ANY OF THEM ANY OBLIGATION OR LIABILITY OTHER THAN AS IS EXPRESSLY SET FORTH HEREIN.

The duration, terms and conditions of this warranty are valid worldwide, except where different limitations, restrictions or conditions may be required by local law.

Australia Residents Only:

Our goods come with guarantees that cannot be excluded under the Australian Consumer Law. You are entitled to a replacement or refund for a major failure and for compensation for any other reasonably foreseeable loss or damage. You are also entitled to have the goods repaired or replaced if the goods fail to be of acceptable quality and the failure does not amount to a major failure. The benefits under Fellowes' Warranty are in addition to other rights and remedies under a law in relation to the product.